

Leader in traction technologies

With over 100 years experience in powering transportation, ABB is the leader in traction technologies. Constant innovation drives energy efficiency and productivity while reducing emissions and operating costs. Our fully lifecycle managed propulsion, auxiliary, and energy storage solutions contribute to making transportation more sustainable, while saving energy every day.



Where are we today

- Fossil fuels, CO₂ emissions, increasing governmental regulations
- Noisy work environment, with noxious fumes
- Low energy efficiency, much wasted heat
- Mechanical wear and tear, many moving parts

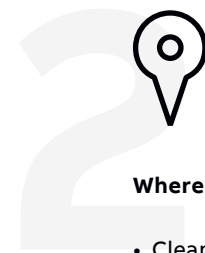

Where are we going

- Cleaner electric vehicles, free of CO₂ emissions, green solution
- Cleaner air and quieter in operator's work zone
- Higher efficiency, reduced heat waste
- Less moving parts, reduced mechanical stresses.



What are the benefits

- Improved health for bystanders
- Less sick leave, better productivity. Less noise disturbances in cities.
- Less overall impact on the local environment, lower operating costs
- Easier service and maintenance, increased uptime and productivity

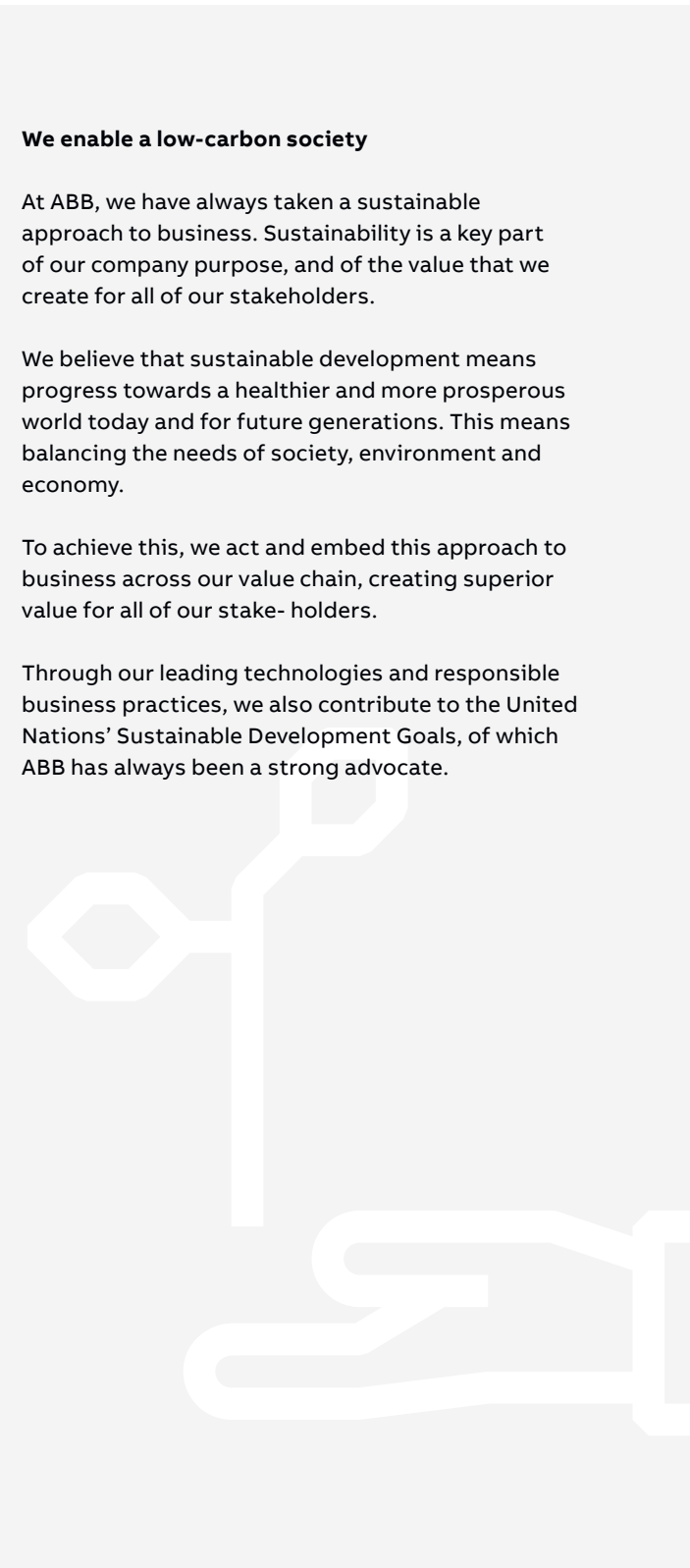

We enable a low-carbon society

At ABB, we have always taken a sustainable approach to business. Sustainability is a key part of our company purpose, and of the value that we create for all of our stakeholders.

We believe that sustainable development means progress towards a healthier and more prosperous world today and for future generations. This means balancing the needs of society, environment and economy.

To achieve this, we act and embed this approach to business across our value chain, creating superior value for all of our stakeholders.

Through our leading technologies and responsible business practices, we also contribute to the United Nations' Sustainable Development Goals, of which ABB has always been a strong advocate.



Harnessflex® offers complete systems solutions for the routing and protection of electrical wiring against damage by mechanical abrasion, liquid ingress and corrosion.

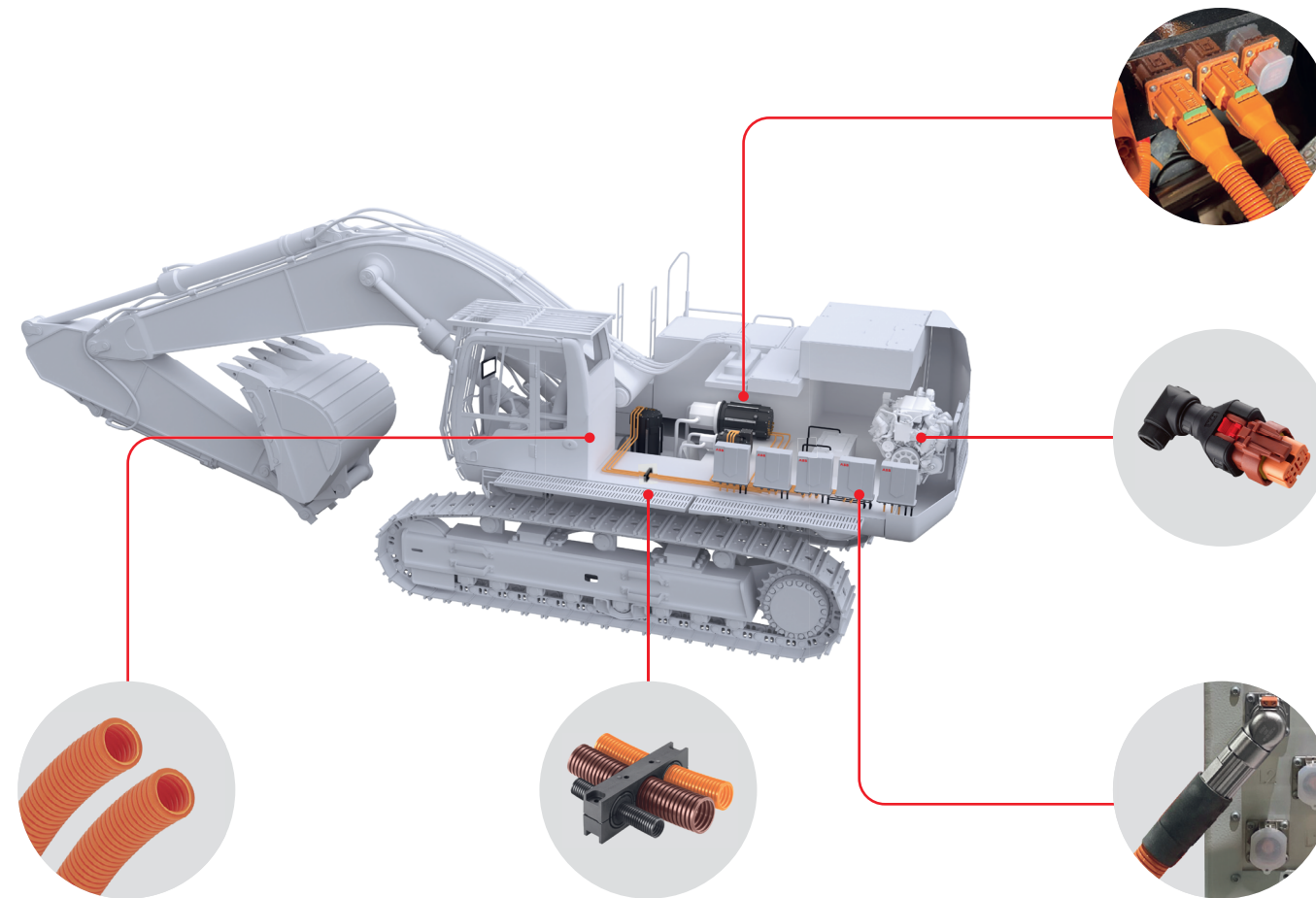

Discover more
ABB Powertrains for sustainable transport

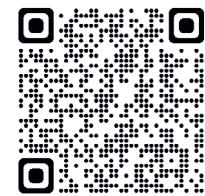

Harnessflex® Specialist Conduit Systems

Protecting critical electrical wiring in heavy automotive vehicles

ABB TRACTION

Electric powertrain solutions for construction equipment



ABB products for construction equipment electrification

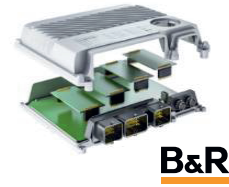

Mobile controllers X90

With the X90 mobile controller, B&R offers automation solutions designed specifically for the critical ambient conditions often present in commercial vehicle and outdoor applications.

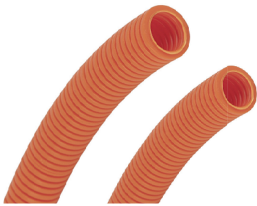

Harnessflex EVO™ Conduit

Suitable for electric vehicle applications, Harnessflex Electric Vehicle Orange Conduit (EVO™) is a flexible nylon that is able to withstand extreme temperatures and is resistant to automotive oils and solvents.

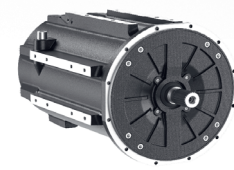
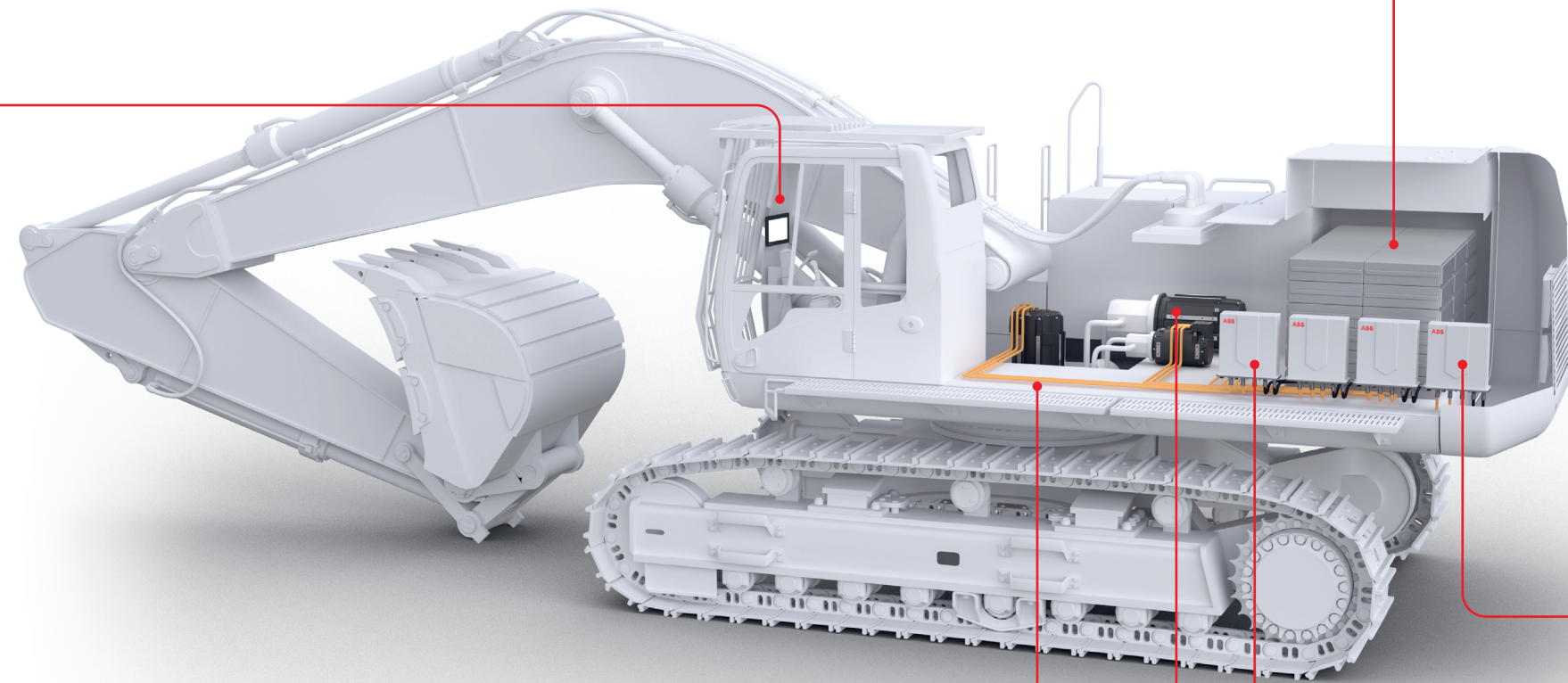

AMXE Motors

Compact, permanent magnet synchronous motors for high efficiency propulsion and auxiliary usage. Power levels range from 20 to 520 kW with a speed reaching up to 8000 rpm.

Additionally, four frame sizes and a variety of shaft and flange dimensions are available. As an added advantage, the motor shaft and the flange can be selected to fit already existing interfaces.



HES880 mobile drive

The HES880 functions as an inverter for traction motor and generator up to 510 kW continuous and up to 760 kW peak electrical power. It offers three different frame sizes with voltage from 320 to 750 VDC–350, 600 and maximum 900 A currents and operates as a bi-directional line converter for grid connectivity. The same module can be used as a line converter, motor inverter or DC/DC converter and is easy to install by only using plug connectors.



BORDLINE® Max Energy Storage System

Energy storage systems are designed according to ABB's long experience in the transportation business. Based on Lithium batteries, these systems provide maximum safety, lifetime, power and performance. This compact and lightweight solution simplifies connectivity and is suitable for multi-string systems with paralleling. Based on its liquid cooling function, it contributes to an efficient thermal management.



NextGen drive

The next generation drive, which uses a 3-level IGBT topology, is the most efficient, universal and motor friendly topology available today. This 3-level topology reduces harmonic motor losses (-75%) at the same switching frequency and reduces voltage stress on motor winding. It also provides the flexibility to separate the drive and motor with cables and inherent fault tolerance. Through reduced common mode voltage it reduces the risk of motor bearing currents.

ABB motor/converter portfolio

Nominal speed	RPM	Length [mm]	Weight [kg]	750		1,000		1,250		1,500		2,000		2,500		3,000		4,000			
				P [kW]	M [Nm]	P [kW]	M [Nm]	P [kW]	M [Nm]	P [kW]	M [Nm]	P [kW]	M [Nm]	P [kW]	M [Nm]	P [kW]	M [Nm]	P [kW]	M [Nm]		
AMXE-132	S-319	71	Cont																		
				Peak																	
					24	153	31	148	37	141	38	121	45	107							
AMXE-160 Gen2	S-418	120	Cont																		
				Peak																	
					42	267	54	256	64	245	66	210	78	186							
AMXE-200	S-550	229	Cont																		
				Peak																	
					69	439			105	400											
AMXE-250	eBus	360	Cont																		
				Peak																	
					112	712			170	650											
AMXE-160 Gen2	L-407	97	Cont																		
				Peak																	
					94	600	126	600	157	600	188	600	251	600							
AMXE-250	L-635	490	Cont																		
				Peak																	
					118	1500	157	1500	196	1500	236	1500	293	1400							
AMXE-200	L-655	287	Cont																		
				Peak																	
					127	811	177	843	210	803	233	741									
AMXE-160 Gen2	L-518	165	Cont																		
				Peak																	
					211	1345			301	1150											
AMXE-200	L-635	490	Cont																		
				Peak																	
					442	2813	524	2503	569	2174	616	1961									
AMXE-250	L-635	490	Cont																		
				Peak																	
					135	860			190	2500											
AMXE-200	L-635	490	Cont																		
				Peak																	
					287	1828	342	1634	357	1365	379	1205									
AMXE-160 Gen2	L-518	165	Cont																		
				Peak																	
					112	712			170	650											
AMXE-200	L-655	287	Cont																		
				Peak																	
					442	2813	524	2503	569	2174	616	1961									

Peak currents



Reliable solutions for harsh environments



Retrofitting existing diesel powertrains to electrical drivetrains with ABB's flexible solutions

In the construction equipment sector, many companies work with retrofitting different types of construction vehicles. An increasing number of E-mobility retrofits are now starting to move forward, resulting in real projects. We are ready to assist and support this transition with both our motors and drives, as well as our deep knowledge in this field



Easy configurability and scalability are key enablers for retrofitting

ABB's electric powertrains give you the key benefits of being easy to install and commission in a safe way. Thus, the retrofit can be done quickly with no requirement for long lead times.



Common features in all ABB motors and drives

- High enclosure protection class IP67
- Withstand heavy vibration and shocks
- Wide ambient temperature range, -40 to +85 °C (-40 to +185 °F)
- Liquid cooling with high liquid input temperature, up to +70 °C (+158 °F)